

TB6560-3N

the Stepper Motor Driver Board

User Manual

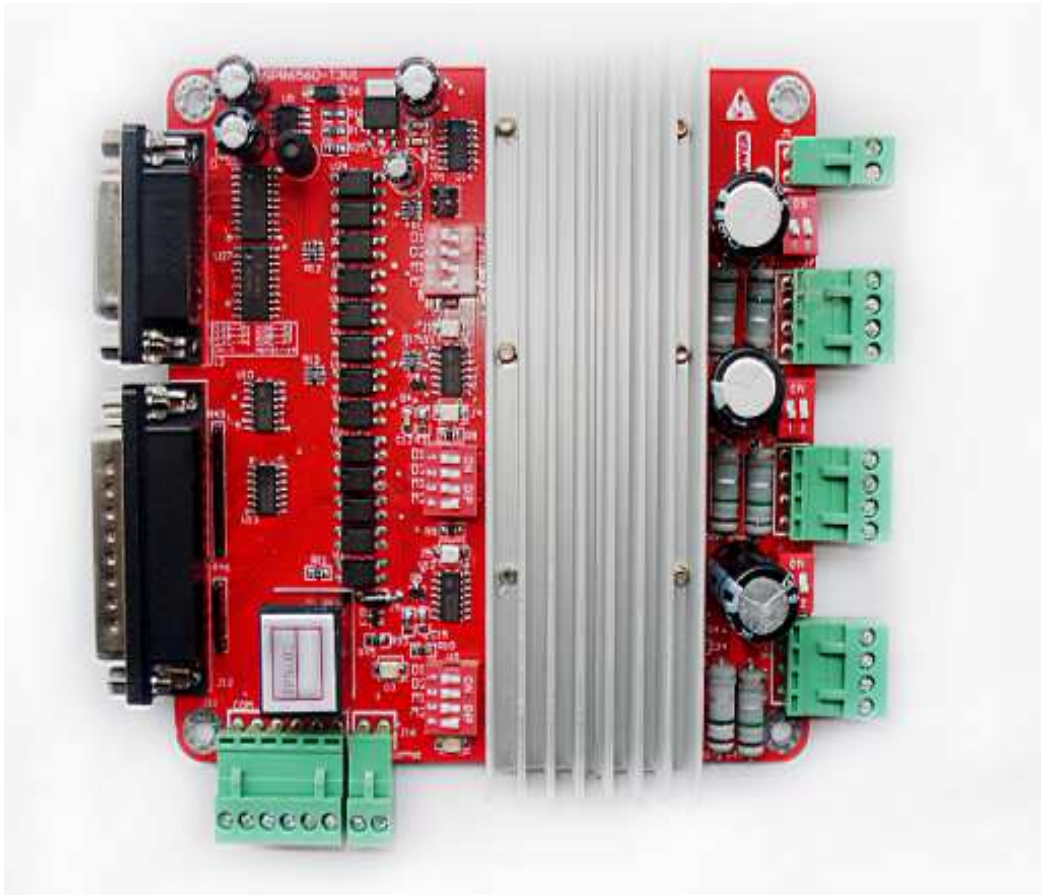

catalog

一 INTRODUCTION	2
1.1 OVERVIEW	2
1.2 TECHNICAL SPECS	2
1.3 APPLICATION DOMAIN.....	3
二 ELECTRICAL, MECHANICAL AND ENVIRONMENTAL SPECIFICATIONS	4
2.1 ELECTRICAL SPECIFICATIONS.....	4
2.2 USE OF THE ENVIRONMENT AND PARAMETERS.....	4
2.3 INSTALL THE MACHINERY (UNIT: MM)	4
三 DRIVE CONNECTION AND INTERFACE DESCRIPTION.....	6
3.1 WIRING DIAGRAM.....	6
3.2 PORT DESCRIPTION	6
四 DIP SWITCH (CURRENT, SEGMENTS, DECAY)	7
4.1 CURRENT SETTINGS.....	7
4.2 SEGMENTS SETTINGS	7
4.3 DECAY MODE	7
五 POWER SUPPLY SELECTION.....	8
六 MATCHING THE MOTOR.....	9
6.1 ELECTRICAL WIRING	9
6.2 INPUT VOLTAGE AND OUTPUT CURRENT SELECTION	9
七 CONTACT US	11

— Introduction

1.1 Overview

The TB6560-3N is a three-axis bipolar 3.0A/phase stepper motor microstepping driver with step and direction inputs, DIP switch settable step mode (full, half, eight and sixteenth—M1/M2), Current (100%, 75%, 50%, 20%—T1/T2), and decay mode (0%, 25%, 50% and 100%-D1/D2).

Using the model of the bipolar constant current chopper technology, makes the motor operation and high precision, small vibration, low noise, stable running, safe and convenient, is the majority of enthusiasts DIY and engraving machine manufacturers preferred products.

1.2 Technical Specs

- Single-chip motor driver for sinusoidal microstep control of stepping motors
- Five limiting interface
- Power on in indication led
- 3Amps-34Volts(Supply voltages:12-34DC)
- Full step, half step, eight step and sixteenth step(selection with M1 M2)
- work Current (0.7A、1.75A、2.6A、3.5A -selection with dipswitches SW1/SW2)
- 4 Wire,6 Wire,8 Wire stepper motors can be used
- Two phases bipolar driver
- Easy wiring with standard screw terminals
- Step frequency up to 100khz
- Standard parallel port interface list for **MACH2**、**MACH3**、**KCAM4**

1.3 Application domain

Suitable for all kinds of small and medium-sized automation equipment and apparatus For example, laser machines, laser engraving &cutting machine, laser subsurface engraving machine, laser handicraft cutting machine, (nonmetal materials) laser marking machine, laser seals engraving machine and photosensitive seal machine.

二 Electrical, mechanical and environmental Specifications

2.1 electrical Specifications

characteristics	Min	Typ	Max	Unit
Input voltage	12	24	34	V
Output current	0.7	2.6	3.5	A
VM Input current	7	10	16	mA
Pulse-frequency	0	50	100	KHz
Insulation resistance	500	--	--	MΩ

2.2 Use of the environment and parameters

Cooling	Natural cooling or forced air cooling	
Use environment	Occasions	Away from heating equipment, combustible gases and conductive dust, avoid dust, oil mist, corrosive gas, place too much humidity and strong vibration
	Temperature	0—+50℃
	Humidity	40—90%RH
	Vibration	5.9m/s ² MAX
Storage temperature	-20℃ ~ 80℃	
Weight	110g	

2.3 Install the machinery (unit: mm)

Cooling	Size	Unit
Length	150	mm

width	130	mm
height	25	mm

≡ Drive connection and interface description

3.1 Wiring diagram



图 1 wiring diagram

3.2 Port Description

3.2.1、Control signal interface

PIN	Function	Explain	PIN	Function	Explain
1	EN	Enable control signal	10	L1	Input limit interface 1
2	STEPX	X Pulse signal	11	L2	Input limit interface 2
3	DIRX	X Direction signal	12	L3	Input limit interface 3
4	STEPLY	Y Pulse signal	13	L4	Input limit interface 4
5	DIRY	Y Direction signal	14	RLY	Relay control signal
6	STEPZ	Z Pulse signal	15	L5	Input limit interface 5
7	DIRZ	Z Direction signal	18-25	GND	GND

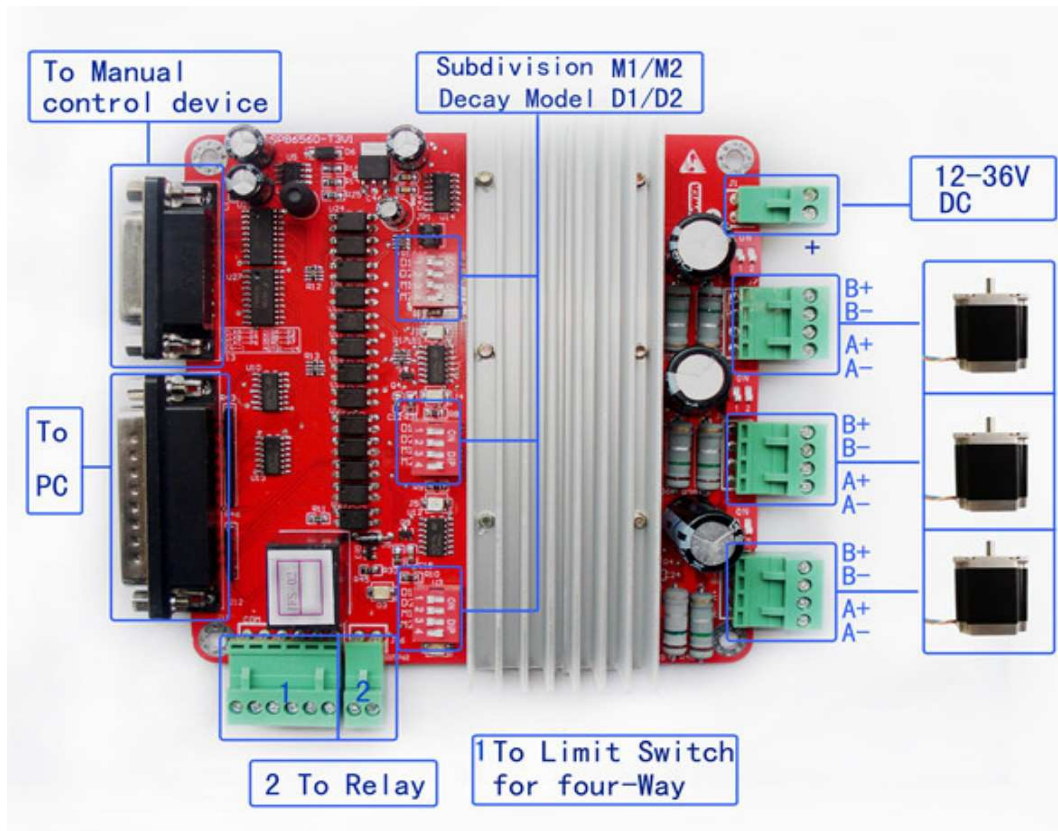
四 DIP switch (current, segments, decay)

The drive using six DIP switch to setting current, segments, decay Mode .

4.1 Current Settings

Switch T1	Switch T 2	current	Explain
ON	ON	20%*3.5A	The current is better to closed to the motor rated current.
OFF	ON	50%*3.5A	
ON	OFF	75%*3.5A	
OFF	OFF	100%*3.5A	

4.2 Segments Settings

Switch M1	Switch M2	Segments	Explain
ON	ON	1/8	When M1 = off, M2 = off, drive segments number is 1,1.8 ° step angle motor turning circle, the whole step = 200 steps / rev. When M1= OFF, S4 = ON,1.8 ° step angle motor turning circle, the whole step = 3200 steps / rev.
OFF	ON	1/16	
ON	OFF	1/2	
OFF	OFF	1	

4.3 Decay Mode

Switch D1	Switch D2	Decay Mode	Explain
ON	ON	Rapid decay	Rapid decay is better when motor has a high speed.
OFF	ON	50%Rapid decay	
ON	OFF	25%Rapid decay	
OFF	OFF	Slow decay	

五 Power supply selection

Power supply voltage DC12V-34V can work, MD430 drive the best use of non-regulated DC power supply, can also be used step-down transformer + bridge + capacitive filter rectifier, capacitor desirable 6800uF or 10000uF. However, note should be rectified peak voltage ripple does not exceed 34V. Recommend the use of 12V-34V DC power supply to avoid power fluctuations over drive voltage range.

If you use a regulated switching power supply, switching power supply should be noted that the output current range to be set to maximum.

Note:

- 1) The wiring should pay attention not to reverse the positive and negative;**
- 2) The best type of non-regulated power supply;**
- 3) use of non-regulated power supply, the supply current output drive capability should be greater than 60% of current can be set;**
- 4) the use of regulated switching power supply, power supply output current should be greater than or equal to the drive current;**
- 5) If electrical power is large enough, two drivers can share a power supply.**

六 Matching the motor

Motor: 4,6,8-line two-phase, four-phase hybrid stepping motor, step angle of 1.8 degrees and 0.9 degrees can be applied.

Selected mainly based on the motor when the motor torque and current rating decision. Torque motor size determined primarily by size. Large size of the motor torque is relatively large; the current size of the primary and the inductance, high-speed performance of small induction motors, but a larger current.

6.1 Electrical wiring

For the 6,8-line stepper motor, connected in different coils of the motor performance quite different, as shown below:

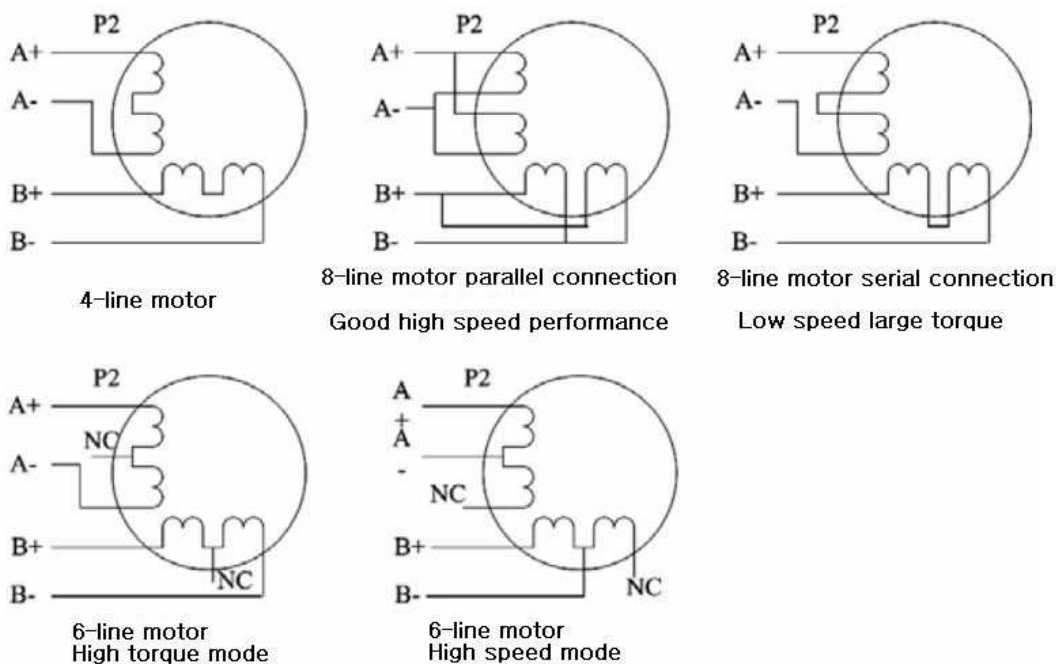

6.2 Input voltage and output current selection

1) Supply voltage setting

In general, the higher the supply voltage, the greater the motor torque at high speed.

High speed to avoid losing steps. On the other hand, the voltage is too high will lead to over-voltage protection, motor heat more, and may even damage the drive. When working at high voltage, low speed movement of the vibration will be larger.

2)Output current setting

For the same motor, the current setting value, the greater the motor output torque, but the current is large motors and drives are also more serious heat. The size of the specific heat value not only with the current setting, but also with the exercise type and duration. The following is configured using the stepper motor rated current value as a reference, but the practical application of best value should be adjusted on this basis. In principle, such as low temperature (<40 °C) is appropriate to increase the current settings as needed to increase the value of the motor output power (torque and speed response).

- four-and six-wire motor speed mode: The output current is set equal to or slightly less than the motor rated current value;

- six-lane high-torque motor mode: the output current is set to motor rated current 70%;

- eight-wire electrical series connection: As the series resistance increases when the output current should be set to motor rated current 70%;

- Motor and eight-wire connection: output current can be set to 1.4 times the rated motor current.

七 Contact Us

Address: High-tech Development Zone, Guangdong Province, Shenzhen

Technical support: 13923726521 13798412235

Email: 723701087@qq.com 190601828@qq.com

Website: <http://vascien.taobao.com/>